



BOYA
BY-WM4 PRO
Dual-Channel Digital Wireless Microphone

Instruction Manual

Thank you for purchasing BOYA BY-WM4 PRO!

Designed for videographers on a limited budget and video hobbyists, BY-WM4 PRO is a new generation 2.4 GHz wireless microphone, dual-Channel for capturing audio with dual subjects to your smartphones, tablets, DSLR cameras, consumer camcorders, PCs etc.

Feature:

- Dual-Channel Wireless Receiver
- Digital 2.4 GHz Frequency Band
- Super-clear recording sound
- Compatible with smartphones, DSLR cameras, consumer camcorders, PCs etc.
- Lightweight and compact for easy carrying
- Omnidirectional lavalier microphone
- Hard case included
- Standard camera shoe mount and clip included
- Up to 60m (197ft) operation range (without obstacle)
- Power supplied by two AAA batteries for transmitter and receiver.

BY-WM4 Pro-K1 consists of one body-pack transmitter(TX4 Pro), a portable receiver (RX4 Pro), and their accessories as following:

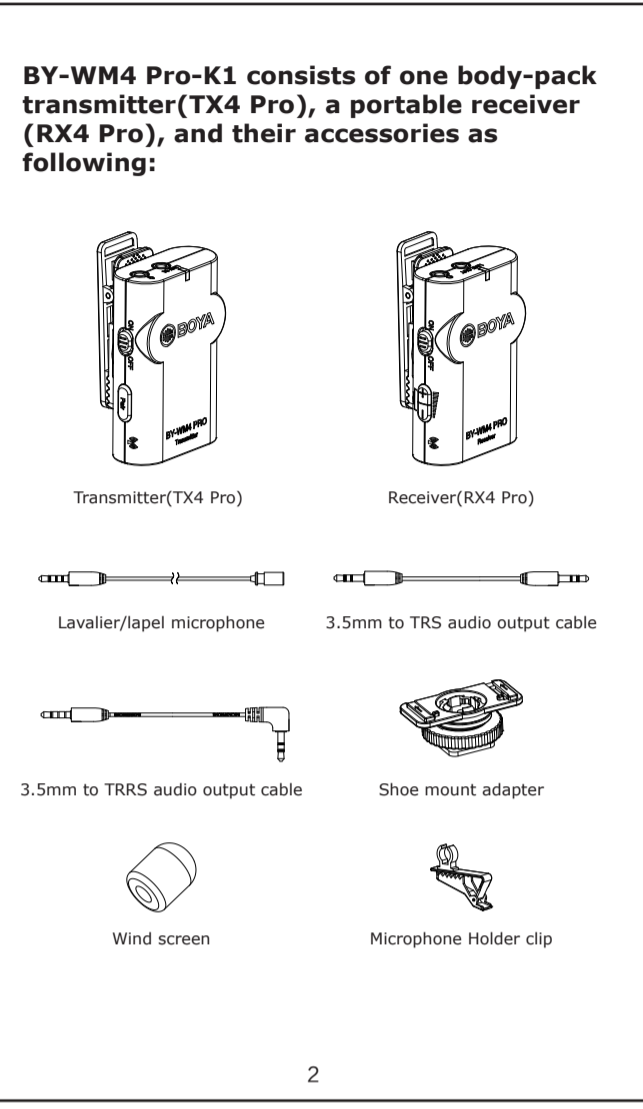

BY-WM4 Pro-K2 consists of two body-pack transmitters(TX4 Pro), a portable receiver (RX4 Pro), and their accessories as following:

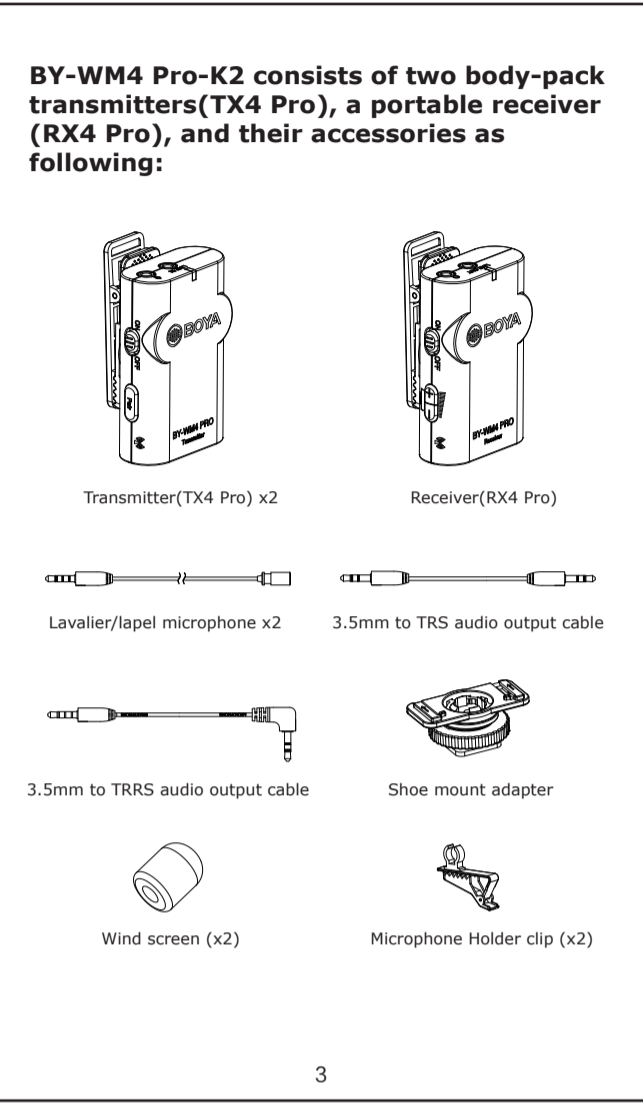

Transmitter (TX4 Pro)

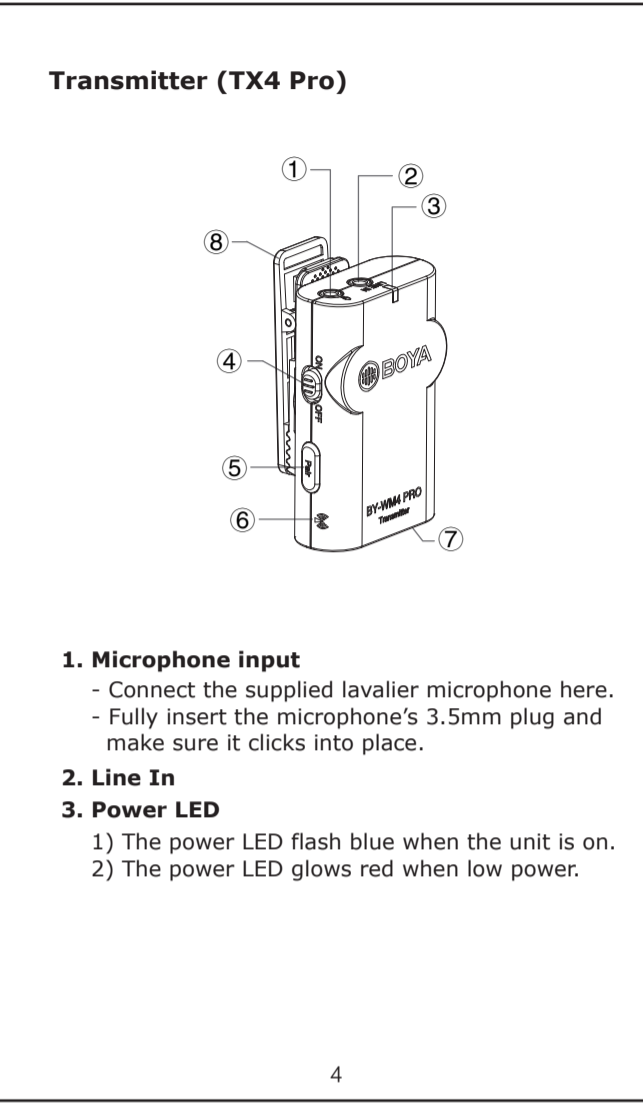

- 1. Microphone input**
- Connect the supplied lavalier microphone here.
- Fully insert the microphone's 3.5mm plug and make sure it clicks into place.
- 2. Line In**
- 3. Power LED**
1) The power LED flash blue when the unit is on.
2) The power LED glows red when low power.

For more details about LED indicator, please refer to as following:

Status	Receiver	Transmitter
The transmitter and the receiver connects.	Stays blue	Flashes continually every 2.5 seconds.
The transmitter and the receiver disconnects.	Flashes continually every 1 second.	Flashes continually every 1 second.
Receiver unit is turned OFF(Transmitter is still ON)	Off	Flashes in blue
Transmitter unit is turned OFF(Receiver is still ON)	Flashes in blue	Off
Low power		Flashes in red

- 4. Power OFF/ON**
5. Pair
This button is for connecting signal.
For details, please see "How to connect transmitter and receiver" on page 11.
- 6. Antenna**
Please don't touch here during using, otherwise, it will effect signal.
- 7. Battery compartment**
Accommodates two pieces of AAA batteries.
For more details, please see "Installing batteries" on page 9.
- 8. Clip**
For more details, please see "Installing or uninstalling clip" on page 13.

Receiver (RX4 Pro)

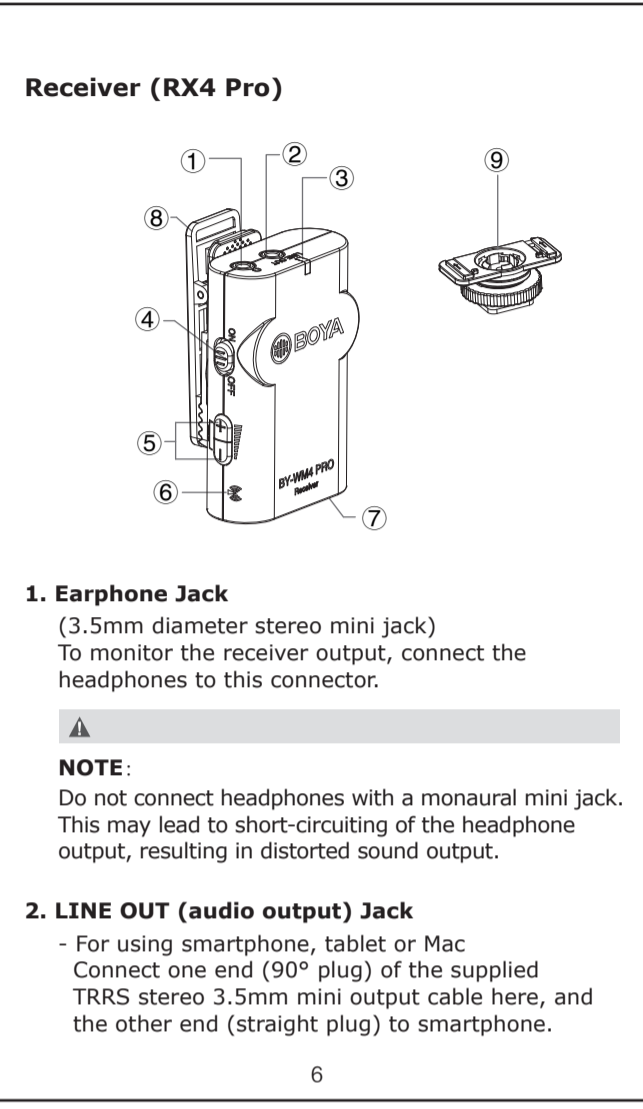

- 1. Earphone Jack**
(3.5mm diameter stereo mini jack)
To monitor the receiver output, connect the headphones to this connector.
- 2. LINE OUT (audio output) Jack**
- For using smartphone, tablet or Mac
Connect one end (90° plug) of the supplied TRRS stereo 3.5mm mini output cable here, and the other end (straight plug) to smartphone.

- For cameras, camcorders, audio recorders and other audio/Video recording devices.
Connect one end of the supplied TRS stereo 3.5mm mini output cable here, and the other end to camera.

3. Power LED
For more details, please see "Power LED" on page 5.

4. Power OFF/ON

5. Volume +/-
Press these buttons to set the attenuation level of the input signal.

6. Antenna
Please don't touch here during using, otherwise, it will effect signal.

7. Battery compartment
Accommodates two pieces of AAA batteries.
For more details, please see "Installing batteries" on page 9.

8. Clip
For more details, please see "Installing or uninstalling clip" on page 13.

9. Shoe mount adapter

What's difference?

- 3.5 mm TRRS connector
- For Smartphone, tablet, Mac or laptop with combo headphone/Mic jack
- 3.5 mm TRS connector
- For cameras, camcorders, audio recorders and other audio/video recording devices.

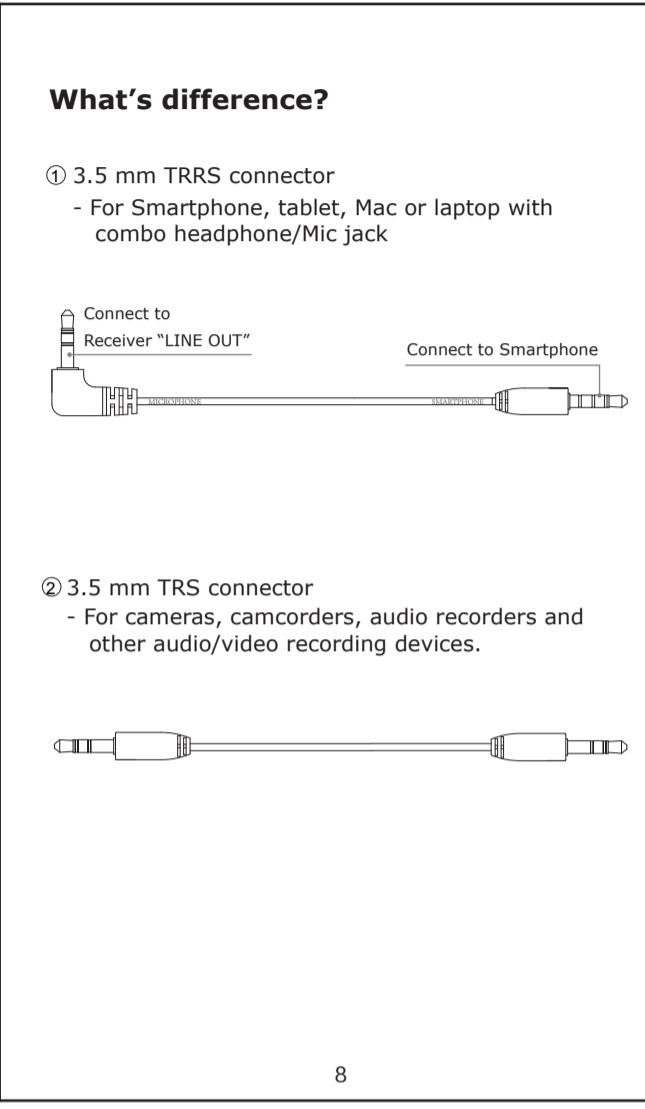

How to use it

Insert batteries in the transmitter and receiver units

- Both transmitter and receiver requires two AAA size batteries.
- Slide and remove the transmitter's battery compartment cover.
- Insert two pieces of batteries.
- Close the battery compartment cover.
- Do the same ways as step 2 to 4 to insert battery into receiver.

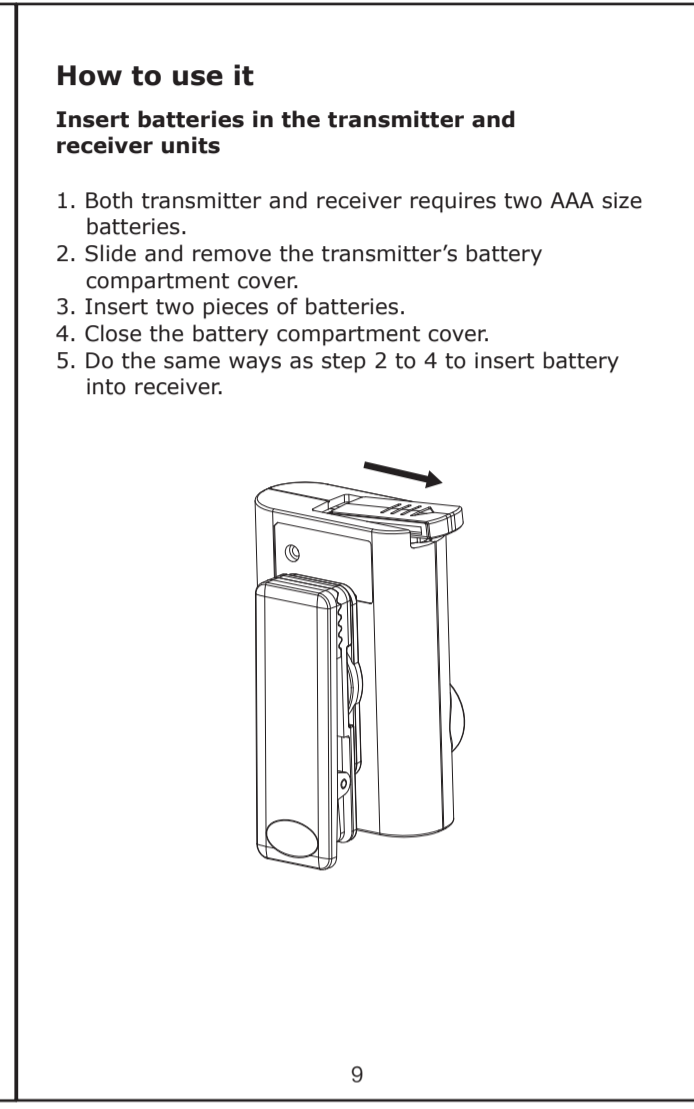

Connecting the transmitter and receiver Using the microphone with smartphone, tablet, Mac or laptop with combo headphone/Mic jack.

Receiver

1. Mount receiver to Smartphone, tablet, Mac or laptop.
2. Using TRRS cable, plug the 3.5 mm connector(straight plug) into the audio jack of your smartphone.
3. Insert the 90° plug of the connecting cable into the receiver "LINE OUT" jack.
4. Insert earphone into receiver " " for monitoring Sound if you need.
5. Slider the power ON/OFF switch to ON position (the LED indicator will light in blue)

Caution: Please do not mix up plug, for details, please refer to "What's difference" on page 8.

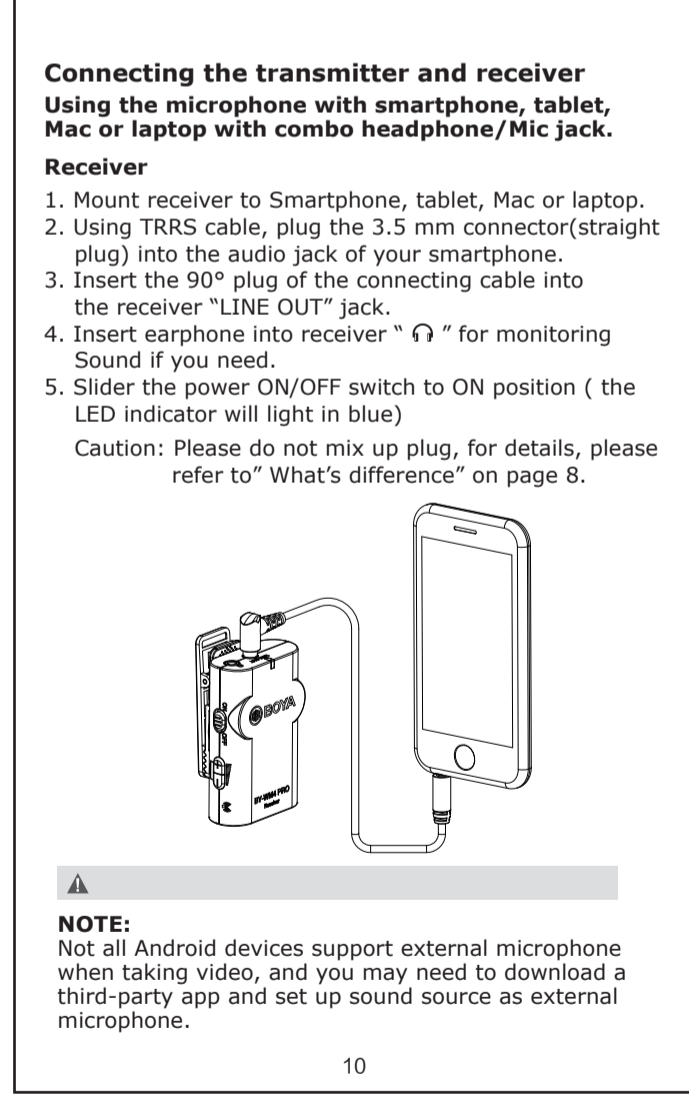

NOTE:
Not all Android devices support external microphone when taking video, and you may need to download a third-party app and set up sound source as external microphone.

Connecting the Transmitters and the Receiver

Before leaving factory, the connection of transmitters and receiver will be established.

If transmitters and receiver disconnect, please follow below steps:

1. Turn on the receiver and the transmitters.
2. Press the button "+" and "-" for 3 seconds for receiver and press "Pair" of one transmitter for 3 seconds at the same time.
3. When transmitter and receiver connects, the light of receiver will stay blue, the light of transmitters will flash every 2.5 seconds.
4. Repeat step 2 for the other transmitter.

Otherwise, the light for receiver and transmitters will flash continually every 1 second, then try 1-4 steps again.

Using the microphone with cameras, camcorders, audio recorders and other audio/video recording devices.

Receiver

1. Mount receiver to cameras, camcorders, audio recorders and other audio/video recording devices.
2. Using TRS cable, plug the 3.5 mm connector into the audio jack of your camera.
3. Insert the other end of the connecting cable into the receiver "LINE OUT" jack.
4. Insert earphone into receiver " " for monitoring Sound if you need.
5. Slider the power ON/OFF switch to ON position (the LED indicator will light in blue)

Caution: Please do not mix up audio cable, for details, please refer to "What's difference on page 8".

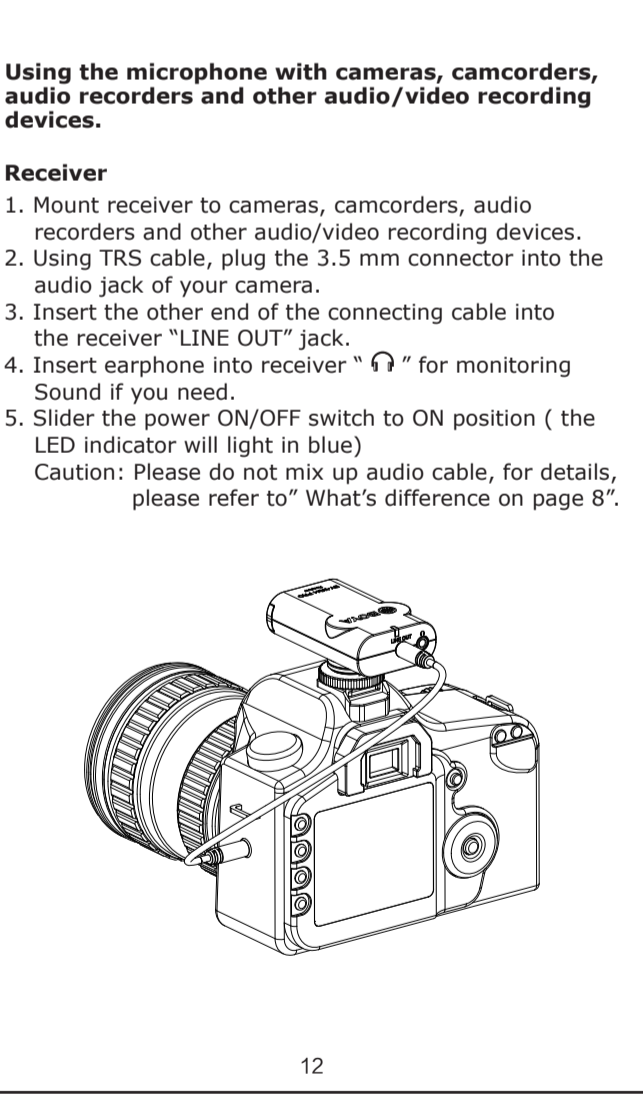

Install microphone

1. Clip is mounted on the microphone before leaving factory.
2. Both transmitter and receiver include clip, that means you can mount them in any place you want.
3. Adjust the direction of the microphone to your mouth by rotating the Microphone.

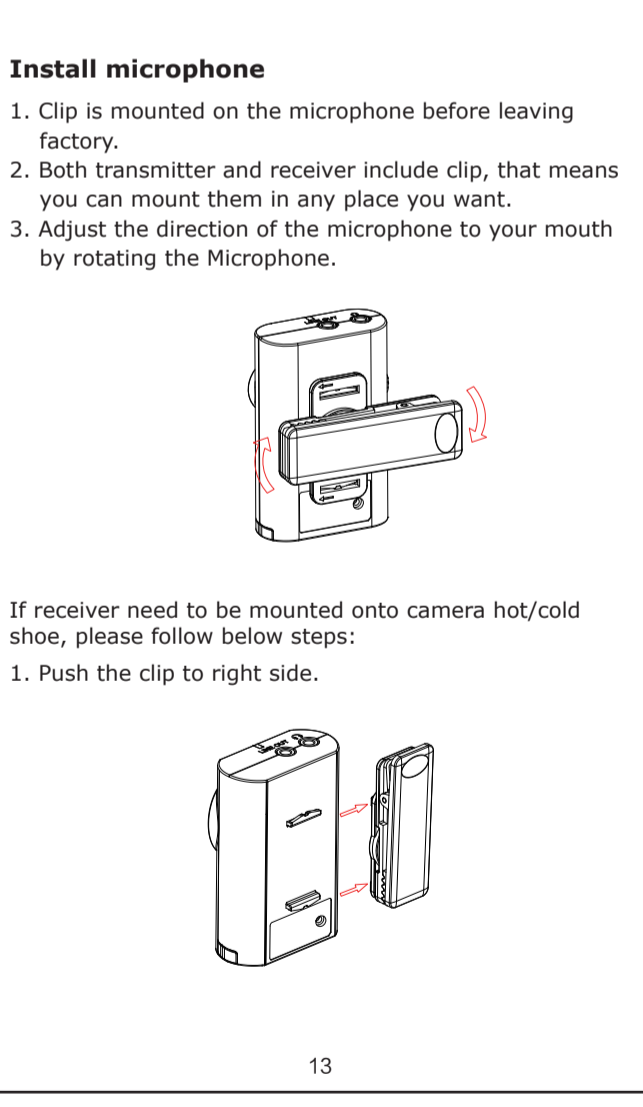

If receiver need to be mounted onto camera hot/cold shoe, please follow below steps:

1. Push the clip to right side.

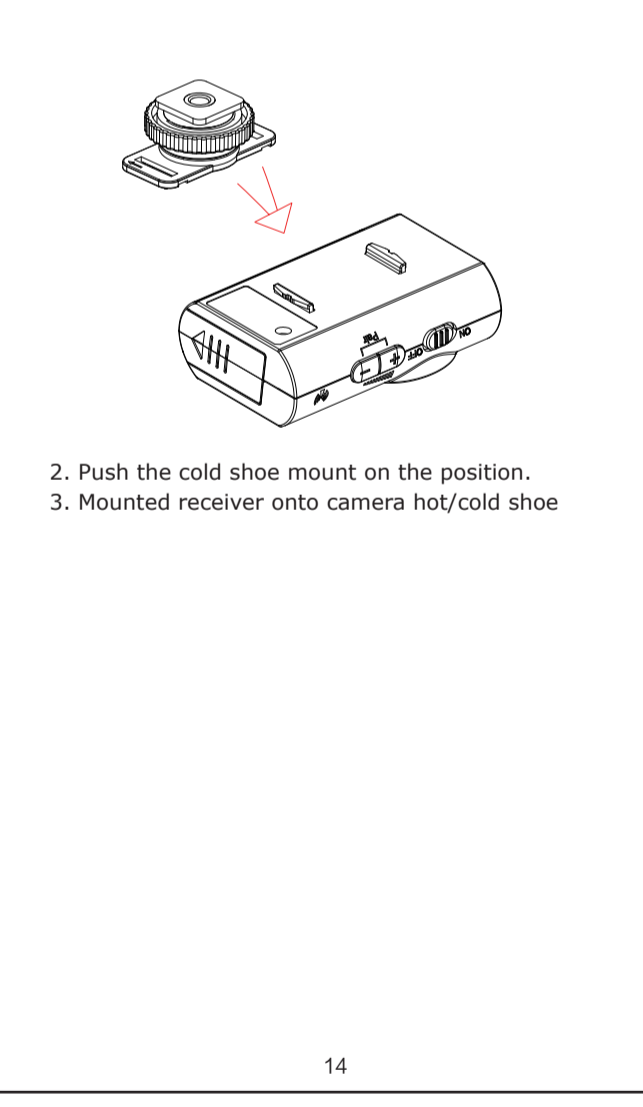

2. Push the cold shoe mount on the position.
3. Mounted receiver onto camera hot/cold shoe

Specifications:

RF Modulation:	GFSK (Gauss Frequency Shift Keying)
Frequency band:	2.4GHz (2405-2478MHz)
Frequency response:	35Hz-14KHz±3dB
Signal/Noise:	84dB or more
Distortion:	0.05% or less (320,1 KHz,65mW output)
RF output level:	3mW
Earphone output level:	32Ω,65mW
Reception sensitivity:	-90dB +/- 3dB / 0dB=1V/Pa, 1kHz
Audio input connector:	3.5mm mini jack
Operation range:	60m (197ft) (without obstacle)
Power requirements:	3V DC (Two AAA size batteries)
Consumption power:	Transmitter: 3V/70mA
	Receiver: 3V/70mA
Dimensions:	Receiver: 45x70x35mm (1.8*2.8*1.4 inches)
	Transmitter: 45x70x35mm (1.8*2.8*1.4 inches)
Weight:	Receiver: 47g (1.7 oz)
	Transmitter: 47g (1.7 oz)

CAUTION

1. Please use our original audio signal cable which is equipped, it's more compatible with the wireless microphone, and make the sound better.
2. The figure given is only the approximate value that applies when there are no obstructions between the transmitter and receiver. This distance will vary depending on metal objects, people and other obstructions and on the signal strength.
3. Battery life may vary depending on the type of battery used.

IMPORTANT

- If you do not intend to use the wireless microphone for a long period time, please remove the batteries from both the transmitter and receiver.
- Do not touch the lavalier/lapel microphone, transmitter and receiver while recording, as this will cause noise to be recorded.
- Do not let the transmitter close to high-voltage equipment or to devices that emit strong electromagnetic fields, otherwise, it may cause the noise to be recorded.
- Do not use or leave the transmitter and receiver in hot, humid places.
- Do not leave the receiver attached to the camera when storing the camera in a case.
- Do not mix up to use the transmitter and receiver.

WARNING

- Keep the wireless microphone out of the reach of children.
- Never use leaking batteries and never expose batteries to excessive heat or fire.

MAINTENANCE

- Do not operate the device with wet hands or feet.
- Clean the equipment only in the way described in the instructions for use.
- Take care to prevent the equipment from dropping down. Make sure that the device is properly fastened and reliably mounted. If the device has dropped down on the floor have it inspected by a skilled electrician before you switch it on again.
- Should the equipment be damaged or defective, or if you notice a scorching smell: Interrupt the electric power supply immediately by removing the batteries. Do not operate the device with a damaged housing, do not repair the device yourself. Have the device only repaired by a skilled electrician.
- Always keep your device in good condition, as specified in these in-structions for use.
- Do not open the device.

WARNING

FCC STATEMENT :
This device complies with Part 15 of the FCC Rules. Operation is subject to the following two conditions:
(1) This device may not cause harmful interference, and
(2) This device must accept any interference received, including interference that may cause undesired operation.

Warning:
Changes or modifications not expressly approved by the party responsible for compliance could void the user's authority to operate the equipment.

NOTE:
This equipment has been tested and found to comply with the limits for a Class B digital device, pursuant to Part 15 of the FCC Rules. These limits are designed to provide reasonable protection against harmful interference in a residential installation. This equipment generates uses and can radiate radio frequency energy and, if not installed and used in accordance with the instructions, may cause harmful interference to radio communications. However, there is no guarantee that interference will not occur in a particular installation. If this equipment does cause harmful interference to radio or television reception, which can be determined by turning the equipment off and on, the user is encouraged to try to correct the interference by one or more of the following measures:
Reorient or relocate the receiving antenna.
Increase the separation between the equipment and receiver.
Connect the equipment into an outlet on a circuit different from that to which the receiver is connected.
Consult the dealer or an experienced radio/TV technician for help.

RF warning statement:
The device has been evaluated to meet general RF exposure requirement. The device can be used in portable exposure condition without restriction

www.boy-mic.com

SHENZHEN JIAYZ PHOTO INDUSTRIAL., LTD.
The BOYA logo is a trademark which is registered and owned by Shenzhen Jiayz Photo Industrial., Ltd.
COPY RIGHT 2010-2020
Email: sales@boy-mic.com
www.boy-mic.com / www.jiayz.com

技术要求:
1、表面无色差
2、无正负公差
3、包装标注尺寸为内尺寸



JIAYZ 长丰 深圳市长丰影像器材有限公司

子件名称	BY-WM4 PRO-K2说明书	版本	V00
子件编号	1F0300300192	材质	105g双铜纸 骑马钉 20p
尺寸	90x145	比例	1:1 单位 mm
设计/日期	吴蒙蒙 2019-6-14	审核	暂无 核准/日期 赵宏亮